

Hi-Tech

HYDROTEL HLP PLUS SERIES

10/32/46/68

Anti-Wear Zinc Free Hydraulic Oil

Product Description

Specifically designed to meet the needs of modern, high pressure, industrial and mobile equipment/earth movers hydraulic systems. The **HI-TECH HYDROTEL HLP PLUS** Series is constructed from selected base oils and a proprietary additive system to provide well balanced performance in a range of applications. The products exhibit exceptional oxidation and thermal stability allowing long oil life and minimized deposit formation in severe hydraulic systems using high pressure, high output pumps. The innovative ultra keep clean performance protects critical hydraulic system components from malfunction, such as tight tolerance servo and proportional valves found in many modern hydraulic systems. The shear stable, high viscosity index allows for a wide operating temperature range maintaining maximum hydraulic efficiency and component protection at both low and high temperatures. Outstanding air release properties provide an added measure of protection in systems with low residence time helping to prevent cavitation damage and micro dieseling. The zinc free anti-wear system provides a high degree of protection in gear, vane and piston pumps while also minimizing deposit formation.

Application

- Industrial and mobile equipment hydraulic systems operating at high pressures and temperatures in critical applications.
- Hydraulic systems subject to deposit build-up such as sophisticated Computer Numerically Controlled (CNC) machines, particularly where close clearance servo-valves are used.
- Systems where cold start-up and high operating temperatures are typical.
- Systems requiring a high degree of load-carrying capability and anti-wear protection.
- Machines employing a wide range of components using various metallurgy.
- Rotary screw compressors in natural gas service.



The **HI-TECH HYDROTEL HLP Plus** Series hydraulic oils provide outstanding hydraulic system efficiency; ultra keep clean performance, and a high degree of fluid durability. The hydraulic efficiency feature can lead to reduced energy consumption for both industrial and mobile equipment /earth movers, reducing operating costs and improving productivity. Their excellent oxidation and thermal stability allows extension of oil and filter change intervals while helping to ensure clean systems. Their high level of anti-wear properties and excellent film strength characteristics result in a high degree of equipment protection that not only results in fewer breakdowns but helps improve production capacity.

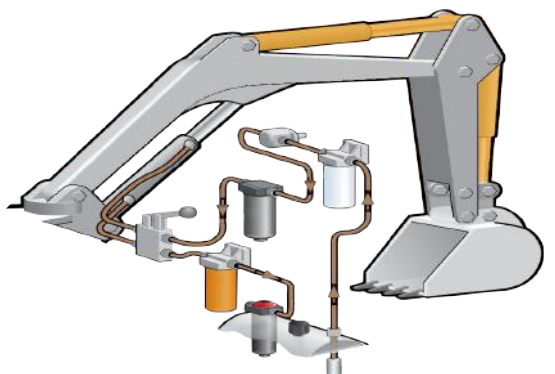

Hi-Tech

HYDROTEL HLP PLUS SERIES

Feature & Potential Benefits

<p>Excellent Hydraulic Efficiency Potentially reduced energy consumption or increased system responsiveness</p>	<p>Ultra Keep Clean Performance Reduced system deposits leading to reduced machine maintenance and increased component life</p>	<p>Shear Stable High Viscosity Index Sustained component protection over a wide temperature</p>	<p>Oxidation and Thermal Stability Extends fluid life even under harsh operating conditions</p>
<p>Good Compatibility with Elastomers and Seals Long seal life and reduced maintenance</p>	<p>Anti-Wear properties Helps reduce wear and protects pumps and components for extended equipment life</p>	<p>Excellent Air Separation Characteristics Helps prevent aeration and cavitation damage in low residence time systems</p>	<p>Multi Metal Compatibility Helps ensure excellent performance and protection with a wide variety of component metallurgy</p>

Typical Properties

Hi-Tech Hydrotel HLP Plus Series	10	32	46	68
Viscosity, ASTM D 445, cSt @ 40 °C	10.5	32.7	45.6	68.4
Viscosity, ASTM D 445, cSt @ 100 °C	2.70	5.74	7.30	9.6
Viscosity Index, ASTM D 2270	91	121	121	123
Density 15 C, ASTM D 4052, Kg/L	0.71	0.85	0.85	0.85
Copper Strip Corrosion, ASTM D 130, 3 hrs @ 100 °C	1	1	1	1
Flash Point, ASTM D 92, °C	150	225	228	232
Pour Point, °C	-25	-20	-20	-18

Oxidation Stability Test at High Temperature

*Based on in-house data comparison

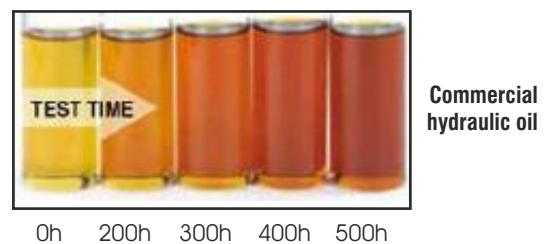
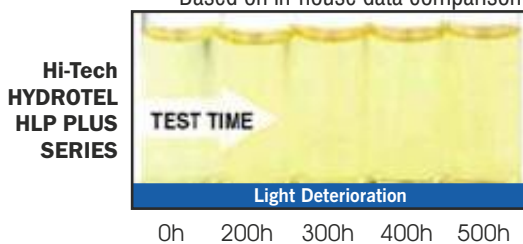

Generation Four Engitech Ltd

Mumbai Roorkee Jodhpur Balotra

Customer Care : 9214048657
Email : en@hitechsolution.co.in
www.hitechsolution.co.in